

11 October 2023

INSTALLATION INSTRUCTIONS (R2.1)**MY22 FVZ/Y AND FVL with EBS:
TRAILER CONTROL VALVE KIT WITH
HARNESS IAL Part No: 92958871****FVZ 240-300 6X4
FVY 240-300 6X4
FVL 240-300 6X2**

NOTE: To be read with latest version of Isuzu Dealer Portal Bulletin 118/23 ENG

CAUTION:

This EBS trailer brake control system kit is designed and developed between Isuzu Japan, Isuzu Australia and Bartlett Towing Solutions specifically for ISUZU MY22 3-axle FVZ, FVY & FVL (unmodified) vehicles. Installation must be carried out by qualified IAL/Dealer approved technicians, programmed using the G-IDSS service tool, then tested and certified by an Approved Vehicle Examiner (AVE) to meet the installation and performance requirements of VSB6 Section G2, Installation of Trailer Braking Controls.

**Caution**Authorised Vehicle
Examiner (AVE)
assessment required**CROSS-REFERENCE:** IAL Part Number 92958871 = BARTLETT KIT TZ9341-10_02**ISUZU AUSTRALIA LIMITED**
ABN 97 006 962 572
Office: 66 Foundation Road, Truganina, Victoria 3029
Correspondence: PO Box 328, Altona North, Victoria 3025
T: (03) 9644 6666 F: (03) 9644 6622
isuzu.com.au

PARTS CHECKLIST -

FVD/FVR EBS TRAILER BRAKING SYSTEM UPGRADE KIT (R2)

ITEM	QTY	PART NUMBER	DESCRIPTION	MASS
1	4	BTU-0125	CABLE HANGER BRACKET	0.018 kg
2	1	BTU-0130	PLATE, PBR TYPE COUPLING MOUNTING	0.177 kg
3	2	BTU-0133	MOUNTING PLATE FOR CONNECTORS VARIOUS	0.171 kg
4	1	BTU-0572	BRACKET FOR ISUZU RELAY VALVE	0.794 kg
5	1	BTU-0573	BRACKET FOR ISUZU F SERIES TRAILER CONTROL MODULE	2.294 kg
6	1	BTU-0619	7 PIN TRAILER SOCKET AND INTERCEPTOR HARNESS ISUZU F SERIES	0.168 kg
7	1	BTU-0645	EBS 24 V WIRING HARNESS FOR ISUZU F SERIES TRUCK - GENERAL	1.658 kg
8	1	BTU-0760-01	TUBE IDENTIFICATION TAPE - ORANGE	0.005 kg
9	1	BTU-0760-02	TUBE IDENTIFICATION TAPE - GREEN	0.001 kg
10	1	BTU-0760-03	TUBE IDENTIFICATION TAPE - LIGHT BLUE	0.001 kg
11	1	BTU-0760-04	TUBE IDENTIFICATION TAPE - RED	0.001 kg
12	1	BTU-0911	RELAY RWD VALVE SUBASSEMBLY	1.186 kg
13	1	BTU-0913	REGULATION VALVE SUBASSEMBLY - STRAIGHT AND ELBOW CONNECTORS	0.590 kg
14	1	BTU-0914	EBS TRAILER CONTROL MODULE SUBASSEMBLY	3.050 kg
15	1	BTU-0915	ASM CHECK VALVE SUBASSEMBLY	0.272 kg
16	1	BTU-0916	AIR CHECK VALVE SUBASSEMBLY	0.274 kg
17	1	BTU-0917	BAYONET AIR BRAKE COUPLING ASSEMBLY WITH 12 mm CONNECTORS KIT	1.025 kg
18	1	BTU-0918	3 WAY UNION AND REDUCING BUSH SUBASSEMBLY	0.293 kg
19	1	BTU-1008	Ø8x6 SINGLE WALL NYLON AIRBRAKE TUBING DIN 74324 - BLACK 1900 LONG	0.141 kg
20	1	BTU-1009	Ø12x9 SINGLE WALL NYLON AIRBRAKE TUBING DIN 74324 - BLACK 25650 LONG	0.570 kg
23	60	UCN100108	CABLE TIE 300 x 4.8 mm BLACK	0.003 kg
24	4	UCN100209	WASHER, FLAT ROUND BRIGHT STEEL 5/16 x 1 X 16G, ZINC PLATED	0.006 kg
26	2	UCN100379	PUSH-TO-CONNECT TEE 8 mm	0.052 kg
27	1	UCN100430	ASM ELEC BRACKET	0.438 kg
28	1	UCN100433	INFORMATION MODULE	0.105 kg
29	1	UCN100435	HTR & A/C RELAY	0.034 kg
30	2	UCN100436	PTO CONT RELAY	0.017 kg
31	5	UCN100437	(HEX HEAD FLANGED SCREW M6x16 LONG)	0.006 kg
32	2	UCN100438	(HEX FLANGED NUT M6)	0.004 kg
33	30	UCN100439	BRACKET NUT (HEX FLANGED NUT M8)	0.006 kg
34	20	UCN100440	PIPE BRACKET BOLT (HEX FLANGE HEAD SCREW M8 x 25 LONG)	0.014 kg
35	10	UCN100441	BELT TENSION BOLT (HEX FLANGE HEAD SCREW M8 x 35 LONG)	0.017 kg

INSTALLATION PRECAUTIONS

Follow all standard workshop and occupational health and safety practices during the installation

GENERAL INFORMATION

Before starting this installation, thoroughly read through these installation instructions and then follow the fitting sequence as described.

Check and note any existing marks or damage to the vehicle interior and exterior.

Check that the kit is complete and there are no damaged components

Take all possible precautions to avoid damage to the vehicle during fitting.

Ensure all torque specifications are followed.

Observe all safety precautions for mechanical loading bodies such as tippers and hooklifts

ABBREVIATIONS

- LHS - Left Hand Side
- RHS - Right Hand Side

TOOLS REQUIRED

Installation should be achievable in dealership workshops using standard issue tools.

ISUZU G-IDSS Programming will be required to complete the conversion.

KIT REVISION NOTES

- **Part number revision.** Bartlett part Number TZ9341-10 Becomes TZ9341-10_02 to denote revision 2 kit. Isuzu Part No. is 92958871
- **Deletion of Bendix Double Check Valve from circuit.** In consult with IAL and IAM engineers it is determined that this feature is not required. Re-routing of pneumatic circuit so that air supply to the TCV is taken from the primary (rear axle) air circuit and the spring brake air supply circuit. There is no input from the front brake air circuit as has been common practise in the past.
- **Nylon air brake tubing** is now supplied in 'total' lengths to suit longest wheel bases and rear overhangs and they are un-marked.
- **Vinyl adhesive coloured strips** have been added for installers to identify nylon tubing circuit branches in accordance with Isuzu practice.
- **Installation instructions** updated

MOUNT TRAILER INFORMATION MODULE (TIM)

LHS Dash.

Remove plastic dash covers LHS exposing dash components

Parts Required:

- ITEM 27** ASM ELEC BRACKET (1)
- ITEM 28** TRAILER INFORMATION MODULE (TIM) (1)
- ITEM 31** HEX HEAD FLANGED SCREW M6x16 (5)
- ITEM 32** HEX FLANGED NUT M6 (2)

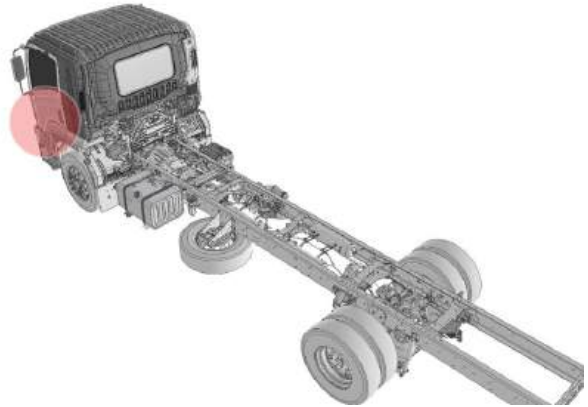

Bolt TIM to mounting bracket using 6mm nuts



Install bracket to dashboard as pictured using M6 bolts

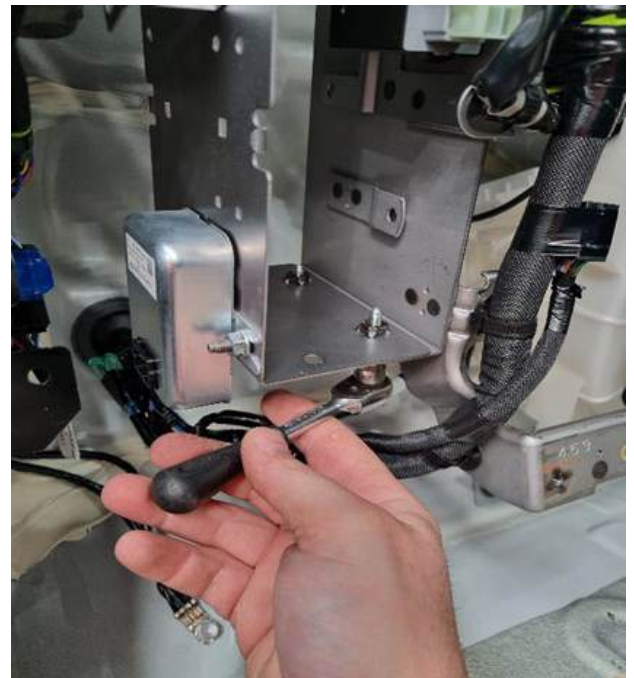

Locate TIM Harness RHS taped to dash loom, remove tape to separate.



Plug connector into TIM, secure existing loom with cable ties.

Reinstall dash plastics.

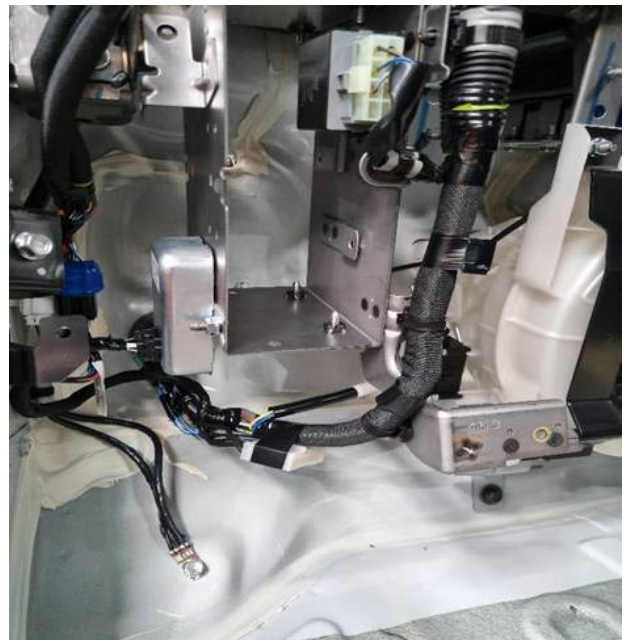

INSTALL RELAYS

Remove dash Fusebox cover



Parts Required:

ITEM 29 HTR & A/C RELAY (1)

ITEM 30 PTO CONT RELAY (2)

Install supplied relays to the relay section LHS of the fuse box as pictured.

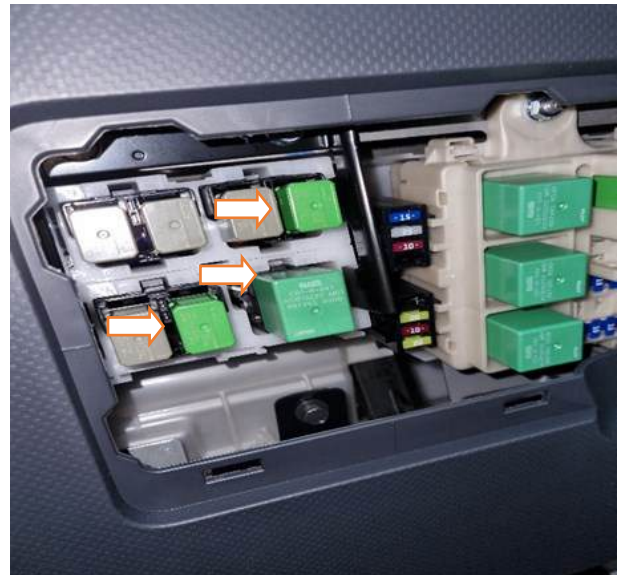

MOUNT REGULATION VALVE

Parts Required:

ITEM 13 REGULATION VALVE SUB-ASSY (1)

ITEM 35 BOLT HEX FLANGE HEAD SCREW
M8 x 35 LONG (2)

ITEM 33 HEX FLANGED NUT M8 (2)

ITEM 8 TUBE IDENTIFICATION TAPE -
ORANGE

ITEM 19 12 X 9 NYLON AIR BRAKE TUBING

STEP 1

Locate air dryer mounting bracket plate (pictured), drill two holes \varnothing 9 mm in accordance with dimensions below.

85 mm in from side edge

25 mm from bottom edge

Regulation valve Hole centres 40 mm

STEP 2

Disconnect and remove Park Brake Tank supply hose indicated by Arrow 1.

Use this tube to create loop from regulation valve elbow fitting (A) to original pressure protection valve. Loop indicated by Arrow 2.

STEP 3

Run 12 mm tube from Regulation Valve elbow fitting (B) to the Park Brake Tank port previously disconnected in Step 2. Tube indicated by Arrow 3. Ensure both ends of tube are marked with single orange tape.

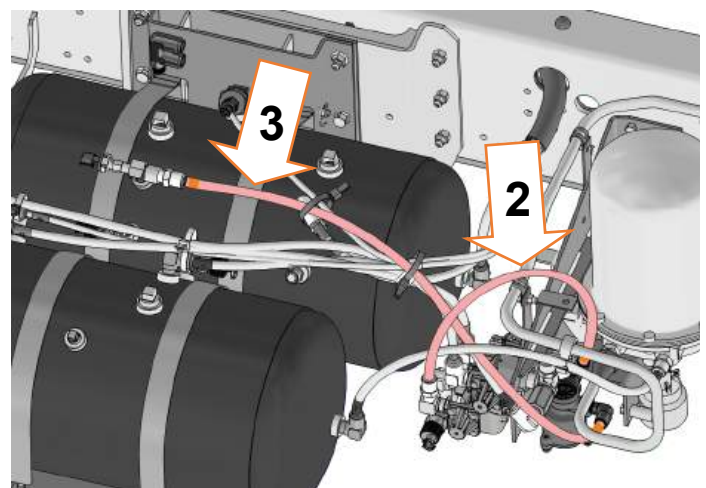
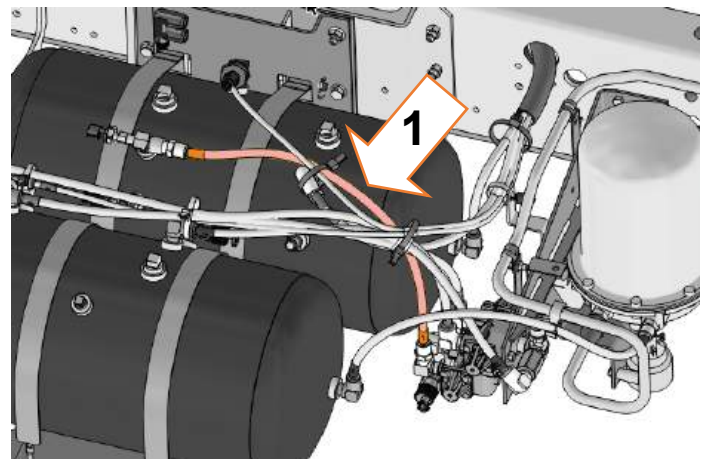
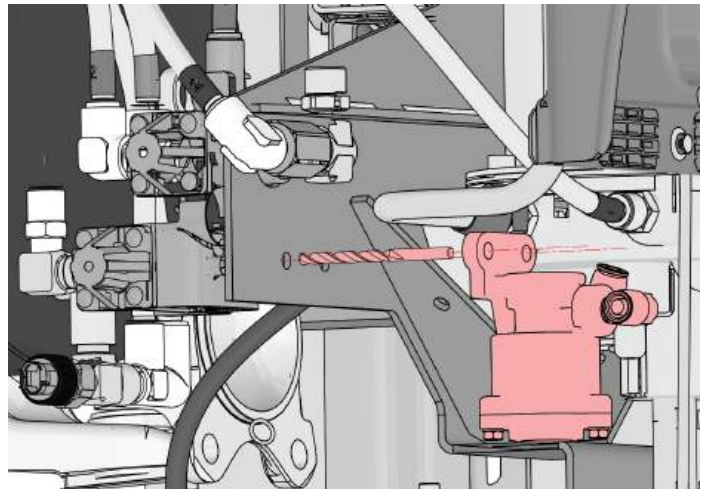
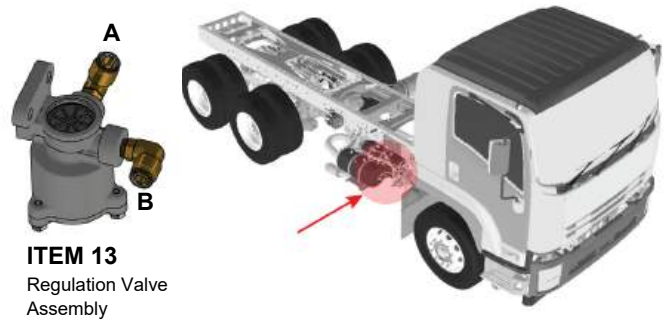

INSTALL PARK BRAKE CHECK VALVE

Parts Required:

ITEM 16 AIR CHECK VALVE SUBASSEMBLY

Locate Park Brake tank and install check valve assembly



Disconnect 8mm airline and fitting , discard fitting.

Install check valve assembly as pictured, be sure to use an Isuzu recommended thread sealant when installing all fittings, once installed

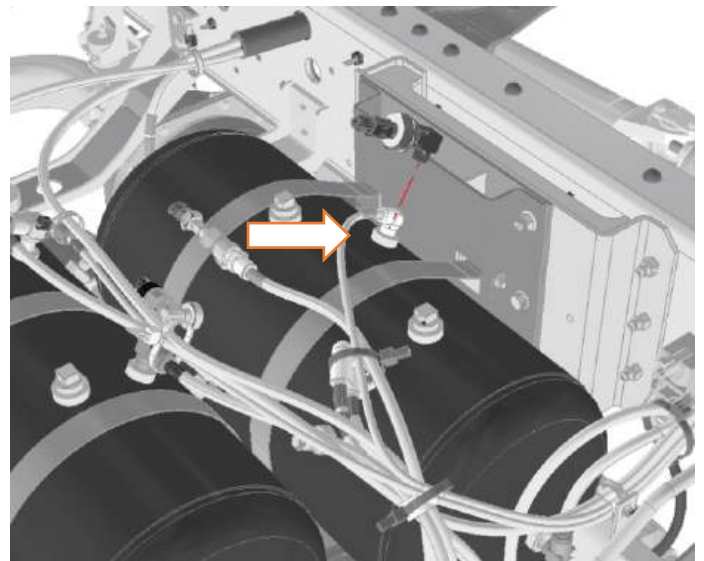

Refit the 8mm airline to the check valve assembly.

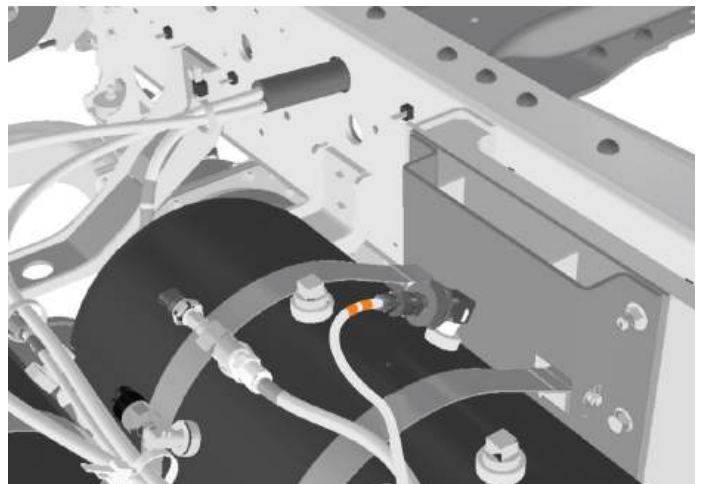

INSTALL TCM SUPPLY

Parts Required:

ITEM 18 3 WAY UNION AND STREET TEE SUB-ASSEMBLY

Remove the 3/4 plug from the top of the park brake tank indicated by arrow right.

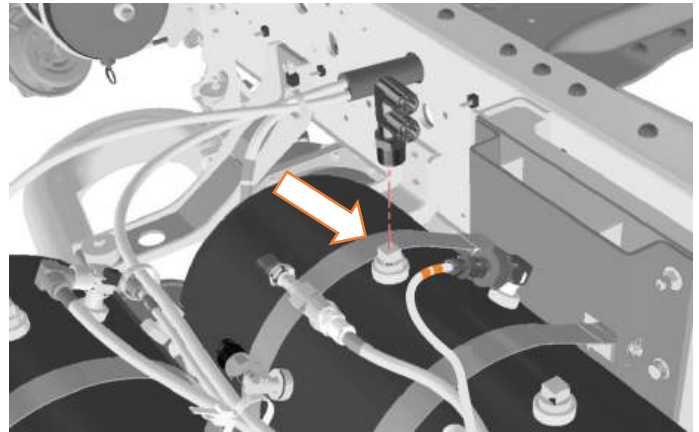

Install 3 way union assembly as pictured below, use recommended thread sealant.

Run two 12 mm tubes to rear of vehicle proximal to TCM. Apply four bands of orange tape to each tube as shown.

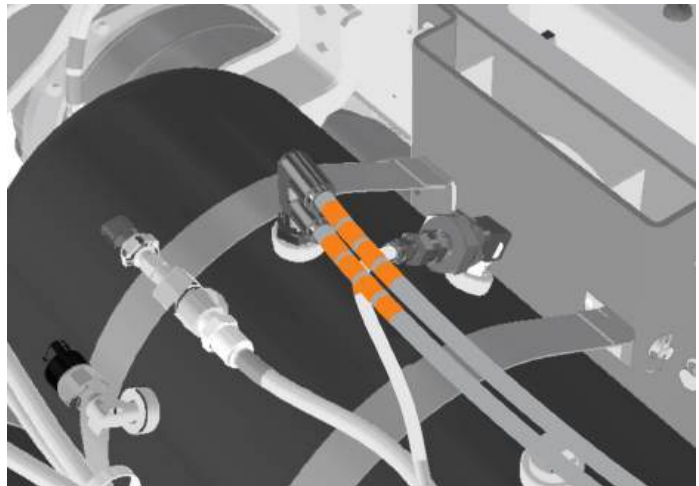

INSTALL CHECK VALVE PARK BRAKE

Parts Required

ITEM 15 ASM CHECK VALVE SUBASSEMBLY

Locate Park brake Relay valve, disconnect 12mm supply line and discard fitting.



Replace supply line fitting with check valve assembly as pictured. Use Isuzu recommended thread sealant



Once installed.

Reconnect 12mm airline as pictured.



INSTALL TCM AND RV MOUNTING BRACKETS

Parts Required

ITEM 4 BRACKET FOR ISUZU RELAY VALVE

ITEM 5 BRACKET FOR ISUZU F SERIES TRAILER CONTROL MODULE

ITEM 33 HEX FLANGED NUT M8 (3)

ITEM 34 HEX FLANGE SCREW M8 x 25 LONG (3)

Bolt valve mounting brackets to indicated cross-member using holes shown. TCM bracket should pick up two existing bolts.

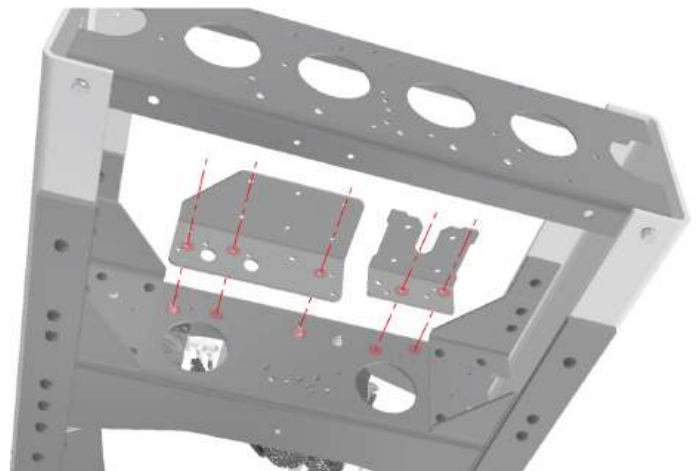
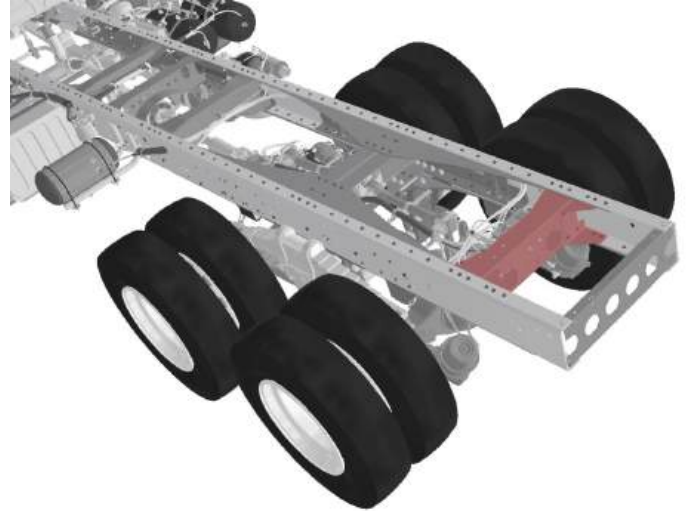

INSTALL TCM AND RV

Parts Required:

ITEM 12 RELAY RWD VALVE SUBASSEMBLY

ITEM 14 EBS TRAILER CONTROL MODULE SUBASSEMBLY

ITEM 33 HEX FLANGED NUT M8 (8)

Attach Relay Valve and Trailer Control Module to the mounting brackets as shown using M8 nuts.

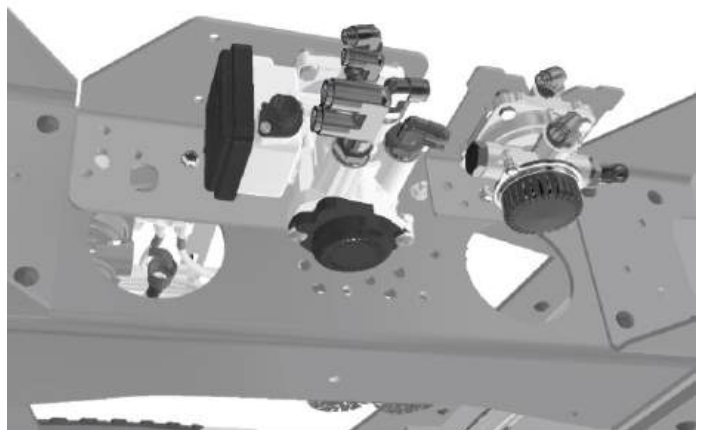

PLUMBING

REAR (PRIMARY) SIGNAL TAP-IN

Parts Required:

ITEM 26 PUSH TO CONNECT TEE 8 mm (1)

ITEM 19 NYLON TUBING 8 mm

ITEM 9 TUBE IDENTIFICATION TAPE - GREEN

STEP 1 Refer picture at right.

Find park brake relay valve as indicated above.
 Tee into the rear primary signal (Line marked with SINGLE green band) using 8mm union tee.

Connect supplied 8mm nylon tube to tee and run proximal to TCM.

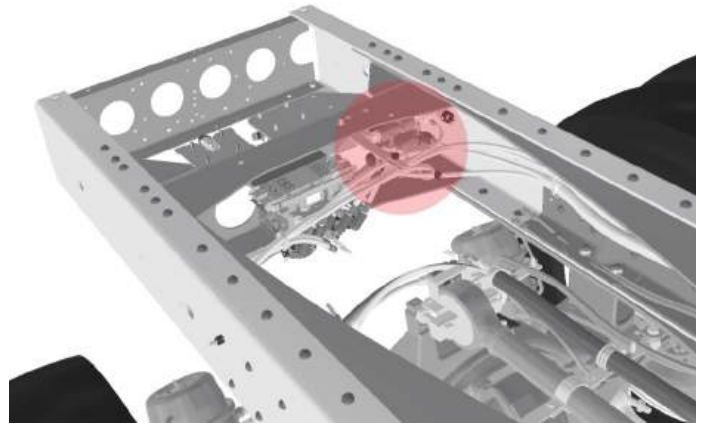

STEP 2

Cut tube and connect the Rear Primary Signal tube to TCM port 42 as pictured right.

Apply single green band of tape, secure length of tube with cable ties.

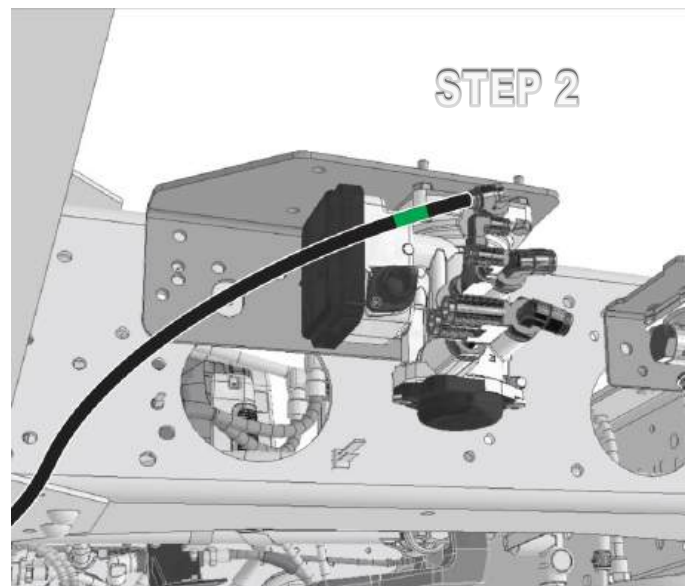

PARK BRAKE SIGNAL TAP-IN

ITEM 26 PUSH TO CONNECT TEE 8 mm (1)

ITEM 19 NYLON TUBING 8 mm

ITEM 8 TUBE IDENTIFICATION TAPE ORANGE

STEP 1 Refer picture at right.

Find park brake relay valve as indicated above. Tee into the Park Brake Signal line (Line marked with SINGLE orange band) using 8mm union tee.

Connect supplied 8mm nylon tube to tee and run proximal to TCM.

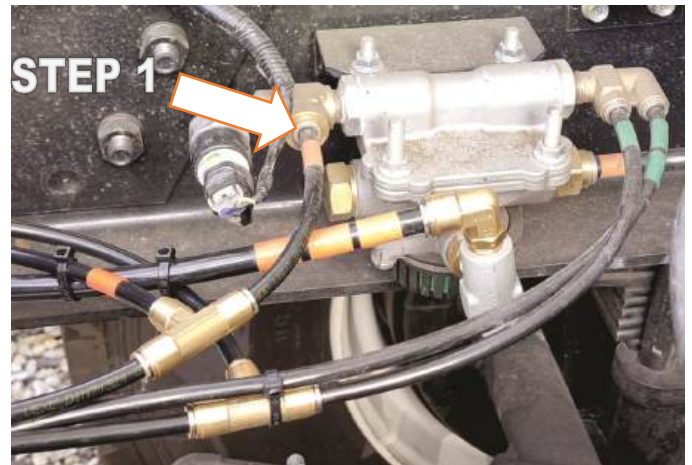

STEP 2

Cut tube and connect the Rear Primary Signal tube to TCM port 43 as pictured right.

Apply single orange band of tape, secure length of tube with cable ties.

STEP 3 Refer picture at right

Connect short length of 8mm tube from the street tee branching from Port 43 to the relay valve Port 4 as pictured. Apply single band of Orange tape at both ends of the run.

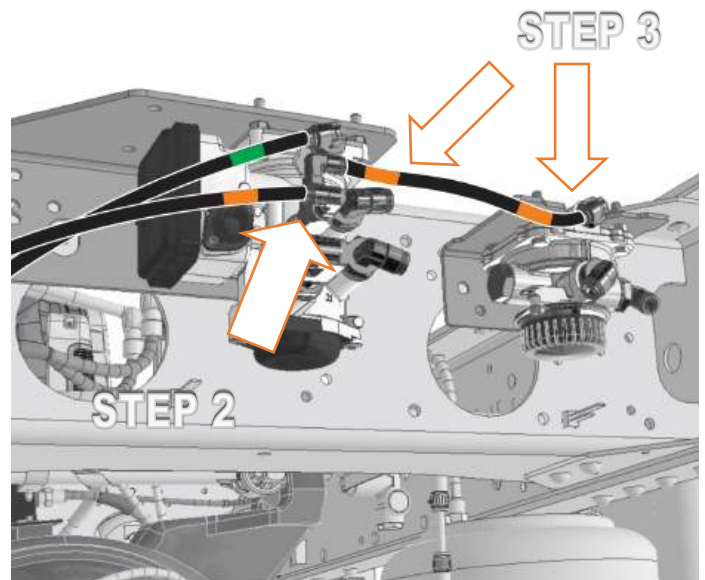

MAIN TCM SUPPLY

Parts Required:

ITEM 20 Ø12x9 SINGLE WALL NYLON AIR-BRAKE TUBING

ITEM 8 TUBE IDENTIFICATION TAPE - ORANGE (16)

Locate the two 12 mm tubes installed page 10.

Cut the 12 mm tubes connect into the TCM 3 way union installed in TCM Port 1. Cable tie tubing as required and apply 4 bands of Orange tape to the end of both tubes.

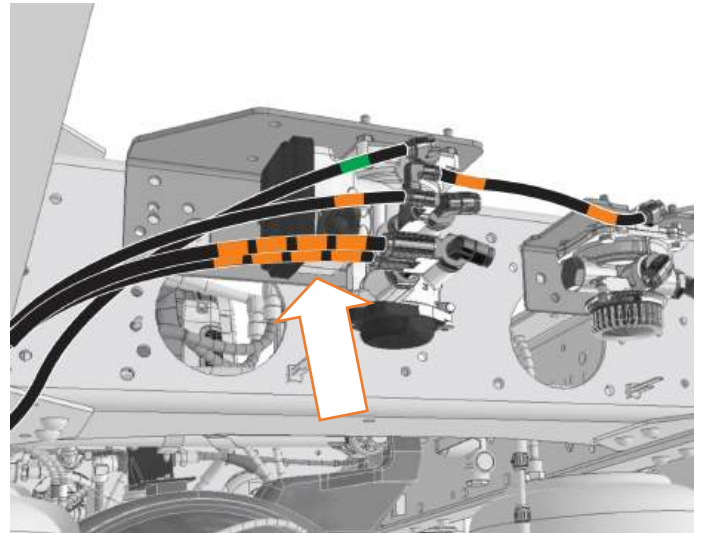

CONNECT TCM TO RELAY

Parts Required:

ITEM 20 Ø12x9 SINGLE WALL NYLON AIR-BRAKE TUBING

ITEM 11 TUBE IDENTIFICATION TAPE - RED (2)

Using short run of 12mm tube create connection between TCV Port 21 and Relay valve Port 1.

Apply single band of Red tape at each end of the tube.

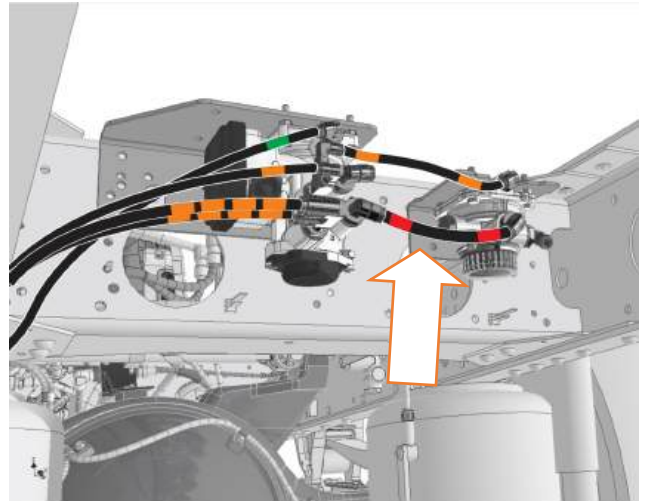

INSTALL SUPPLY AND CONTROL LINES

Parts Required:

ITEM 20 Ø12x9 SINGLE WALL NYLON AIR-BRAKE TUBING

ITEM 17 BAYONET AIR BRAKE COUPLING ASSEMBLY

ITEM 11 TUBE IDENTIFICATION TAPE - RED

ITEM 10 TUBE IDENTIFICATION TAPE - BLUE

STEP 1

Connect 12mm tube to TCV Port 22, run to rear of vehicle. Cut to length allowing enough slack to reach all potential positions on a towbar. Connect the other end to the Male bayonet Coupling.

Apply single band of blue tape to each end of this run.

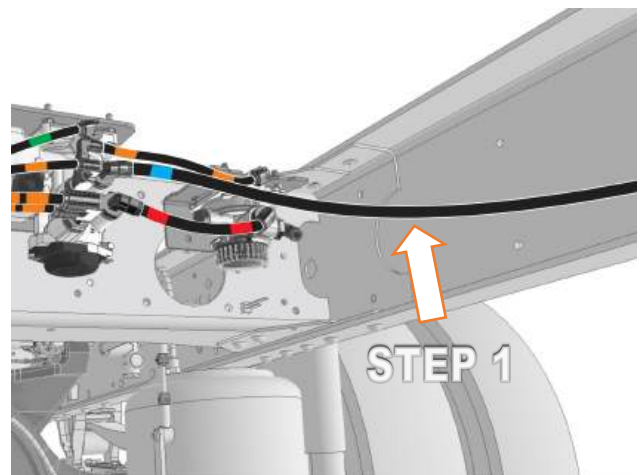

INSTALL SUPPLY AND CONTROL LINES Continued

STEP 2

Connect 12mm tube to Relay Valve Port 2, run to rear of vehicle. Cut to length allowing enough slack to reach all potential positions on a towbar. Connect the other end to the Female bayonet Coupling.

Apply single band of Red tape to each end of this run.

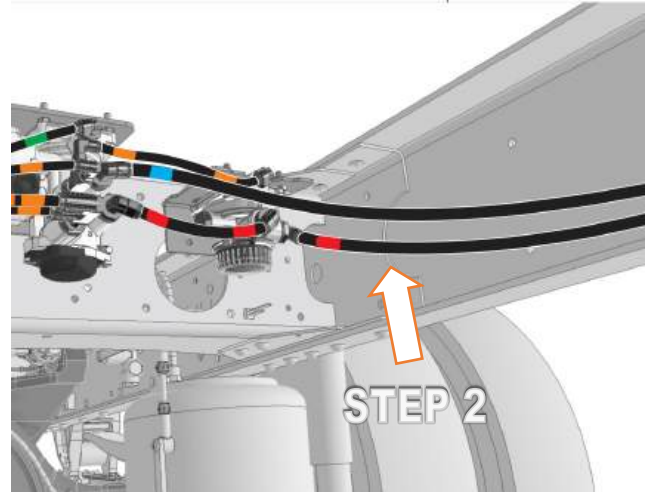

TIE OFF AIR LINES

Parts Required:

ITEM 1 CABLE HANGER BRACKET

ITEM 24 WASHER, 5/16 x 1 X 16G

ITEM 35 BOLT M8 x 35 LONG

ITEM 30 PTO CONT RELAY

Locate parts listed above, bolt hanger brackets to chassis using factory holes on the inside RHS chassis rails, cable tie airlines to clips as pictured.



INSTALL ELECTRICAL HARNESSES

Step 1 Install EBS / Coupling Harness

Step 2 Install Trailer Control Module Harness

Step 3 Install Trailer Lighting Harness

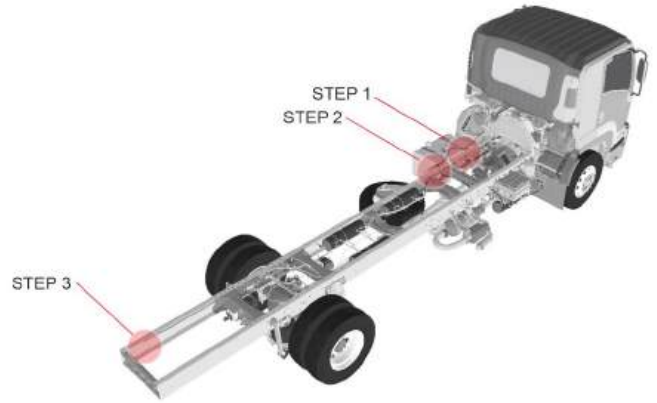

STEP 1 Identify Trailer EBS and CAN connectors.
Remove blank connectors and discard.

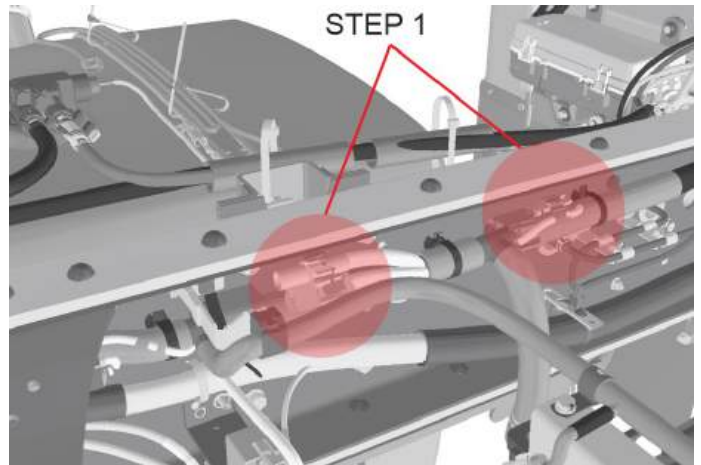

STEP 2 Identify Blank Trailer Control Module connector.
Remove blank connector and discard

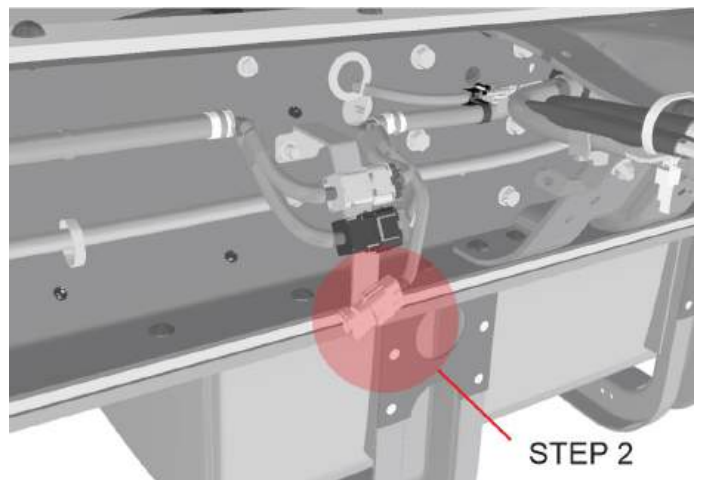

**STEP 1
INSTALL EBS COUPLING
HARNESS**

Parts Required:

ITEM 7 EBS 24 V HARNESS



Refer vehicle position Step 1 page 18.
LHS of chassis approximately 800 mm behind
cabin.

Connect Item 7, EBS Harness as pictured right.

Run harness up LHS chassis rail to rear of vehicle.

If a towbar is not fitted to the truck, tie trailer sockets up to crossmember closest to intended towbar position.

Secure with cable ties and tie up any excess with a loop at this end.

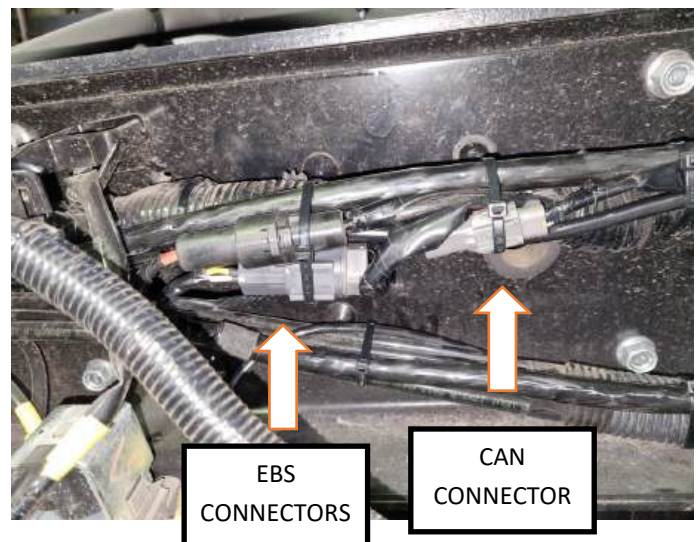

STEP 2 INSTALL TRAILER CONTROL MODULE HARNESS

Parts Required:

Locate factory-supplied Trailer Control Module Harness provided in the cab of the truck (pictured).

Part Number 8977988370



Refer vehicle position Step 2 page 18.

Connect harness to Trailer Control Module connector as shown right.

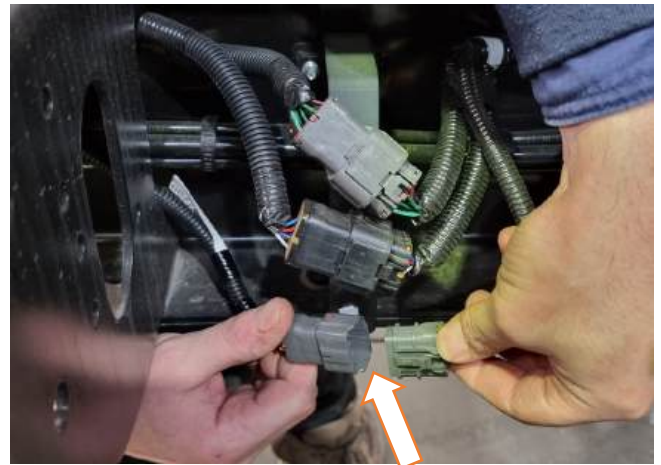

Run harness down the inside LHS chassis rail and connect to the Trailer Control Module (pictured)

Tie up excess harness with cable ties.



STEP 3 INSTALL 7 PIN TRAILER SOCKET HARNESS

Parts Required:

ITEM 6 7 PIN TRAILER SOCKET HARNESS



Refer vehicle position page 18.

LHS rear of chassis.

Disconnect rear taillight harness connectors (pictured right).

Connect 7 Pin trailer socket harness to the trailer lighting harness as pictured.



SECURE COUPLINGS AND CONNECTORS

Parts Required:

ITEM 3 MOUNTING PLATES (2)

ITEM 34 BOLT M8 x 25 LONG (4)

ITEM 30 HEX NUT M8 (4)

Secure any excess harness with cable ties.

Mount the 7 Pin Trailer socket and EBS socket on mounting plates using fasteners listed.

Secure all couplings to rear crossmember.



ISUZU G-IDSS Programming

Isuzu EBS Trailer Brake Control System Programming (Knorr-Bremse) (FTR,FVR,FVD,FVM,FVL,FVZ,FVY)

When a Trailer Control Valve is to be fitted to the above titled EBS Braking System Isuzu vehicles, an EBS Trailer Control Valve Kit will need to be used and once installed, the EBS Trailer Brake Control Valve will need to be programmed into the Knorr-Bremse EBS Braking Module using the GIDSS Diagnostic unit.

Note: GIDSS will require a 24hr Password to access the Knorr-Bremse EBS Programming Section.

Please contact the Isuzu TAS line or your Zone Technical Manager for support.

Note 2: Once the EBS Trailer Control Valve kit has been installed to the vehicle (Not Programmed) the vehicle will log a series of DTC fault codes, once the programming procedure has been completed there will be a EBS Recovery Procedure to be performed and the DTC checked and cleared to complete the programming process. Example of typical DTC's below.

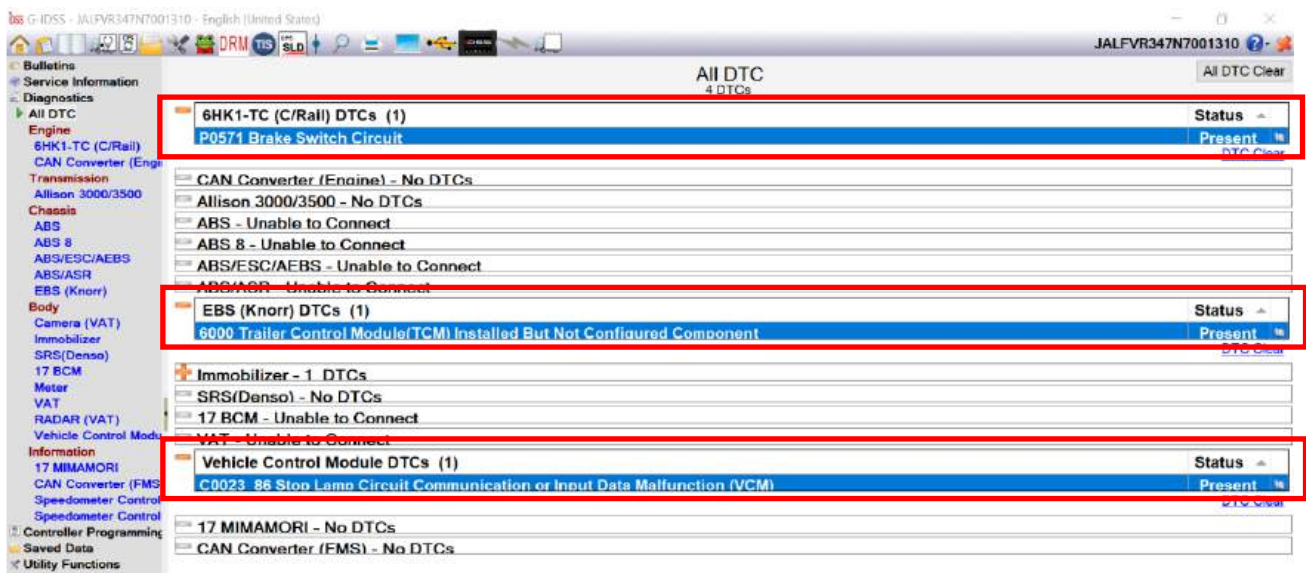

Figure 1 An All DTC Check will likely show the above Diagnostic Trouble Codes as Present. These DTC's will change status to Not Present after the programming is completed. At the conclusion of the programming procedure, clear all DTC's and perform an All DTC Check



Figure 2 The Vehicle will likely have the above Warning Lamps Illuminated.

Select the following Menu Selections from GIDSS to access the EBS (Knorr) Programming Section.

Figure

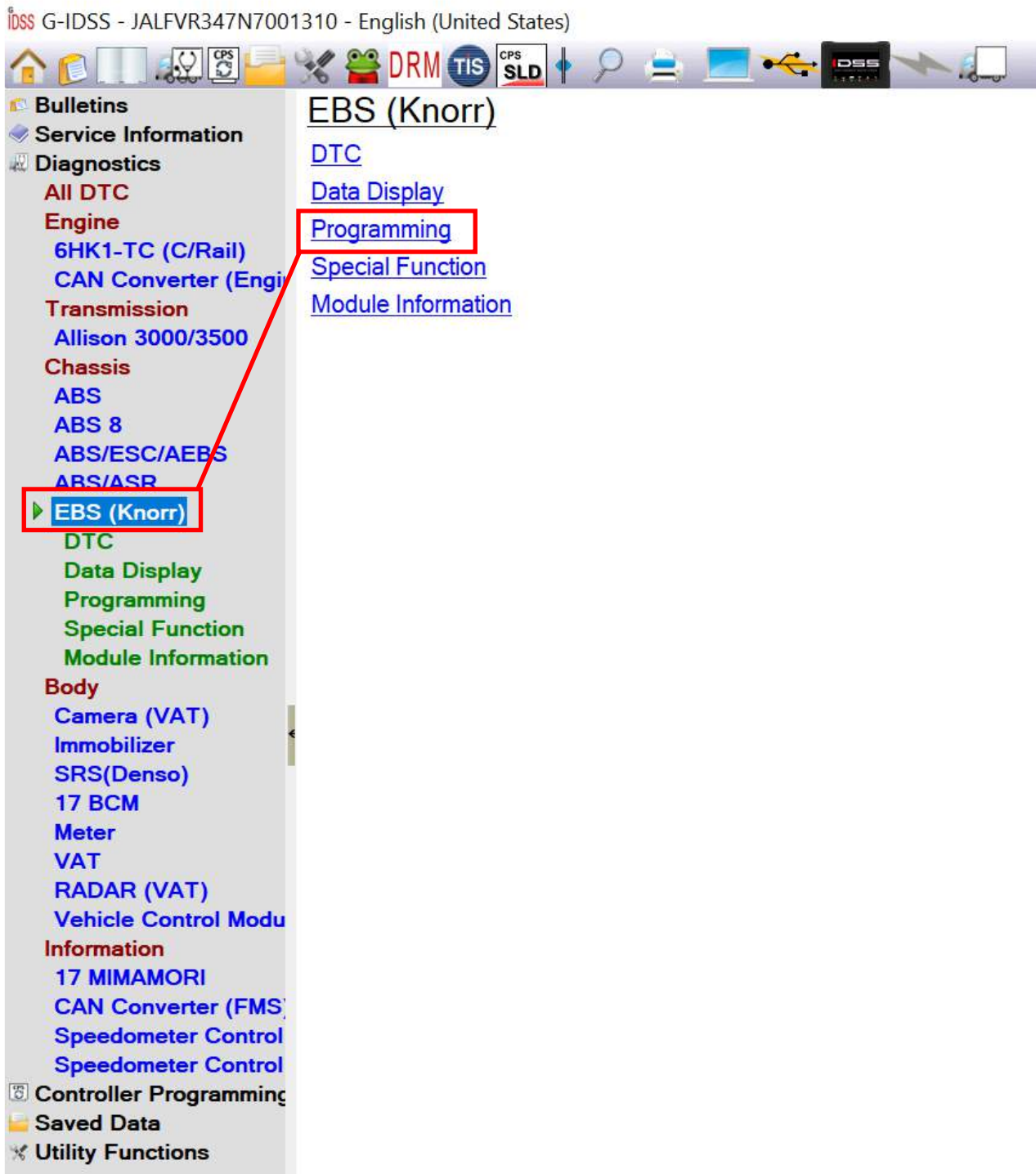

Figure 3 Select EBS (Knorr) from the Diagnostic Menu, then Select Programming.

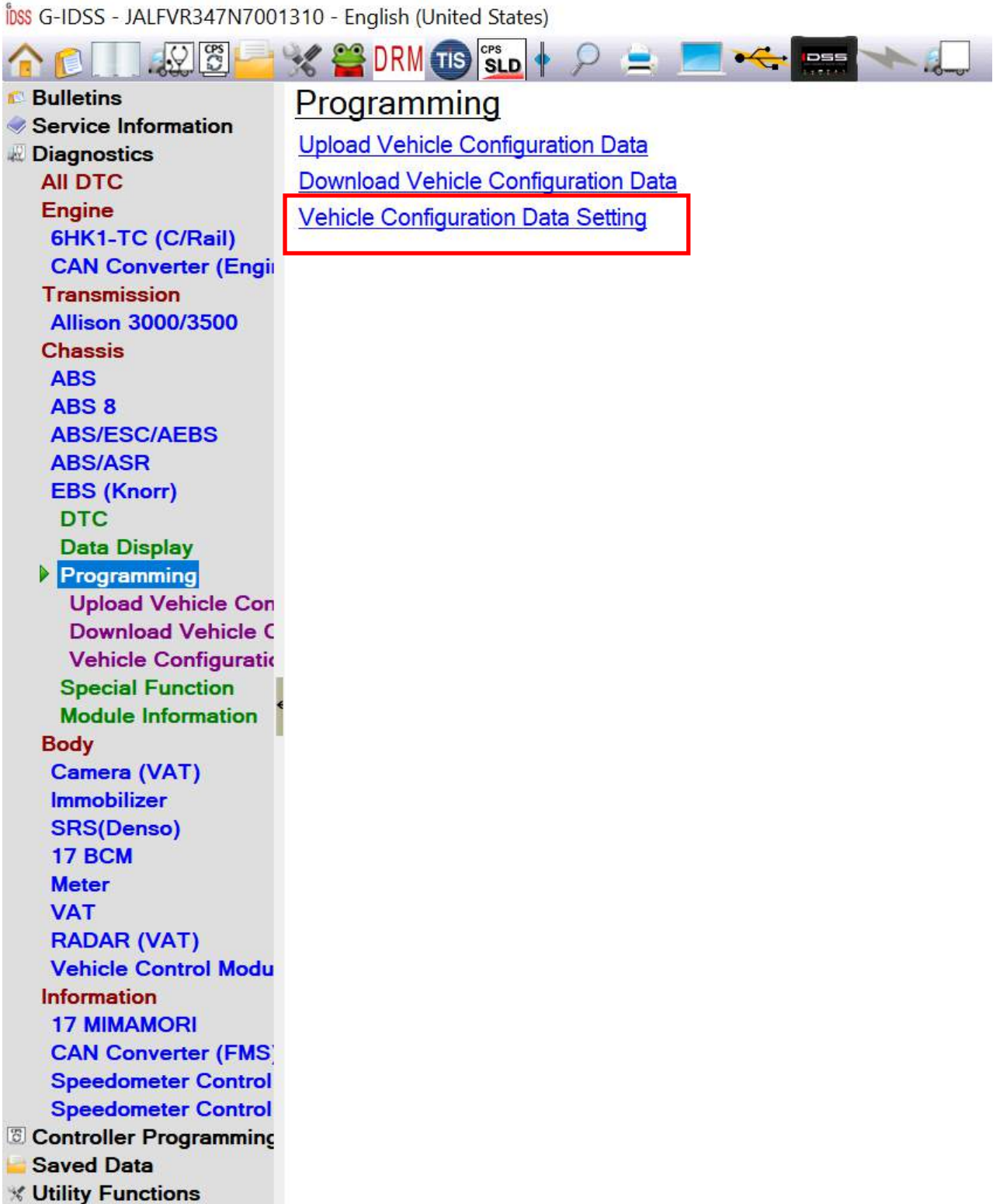

Figure 4 Select Vehicle Configuration Data Setting

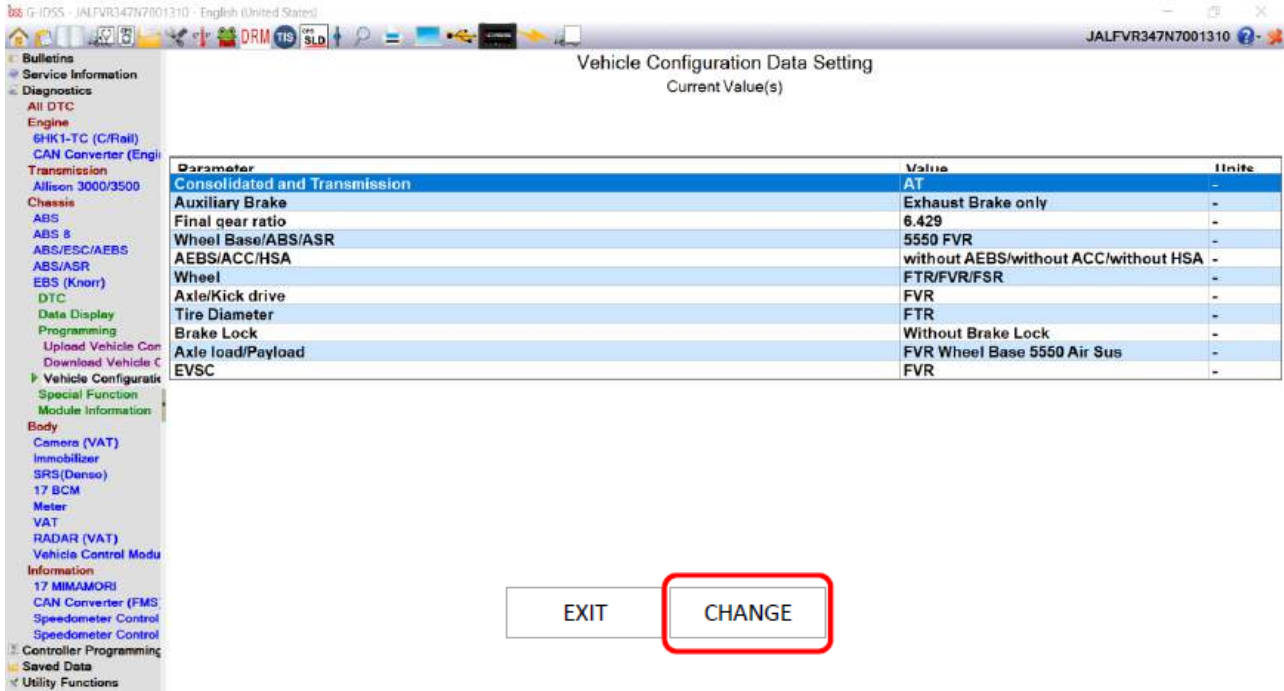

Figure 5 Typical Original Vehicle Configured Settings Select CHANGE to Perform Programming

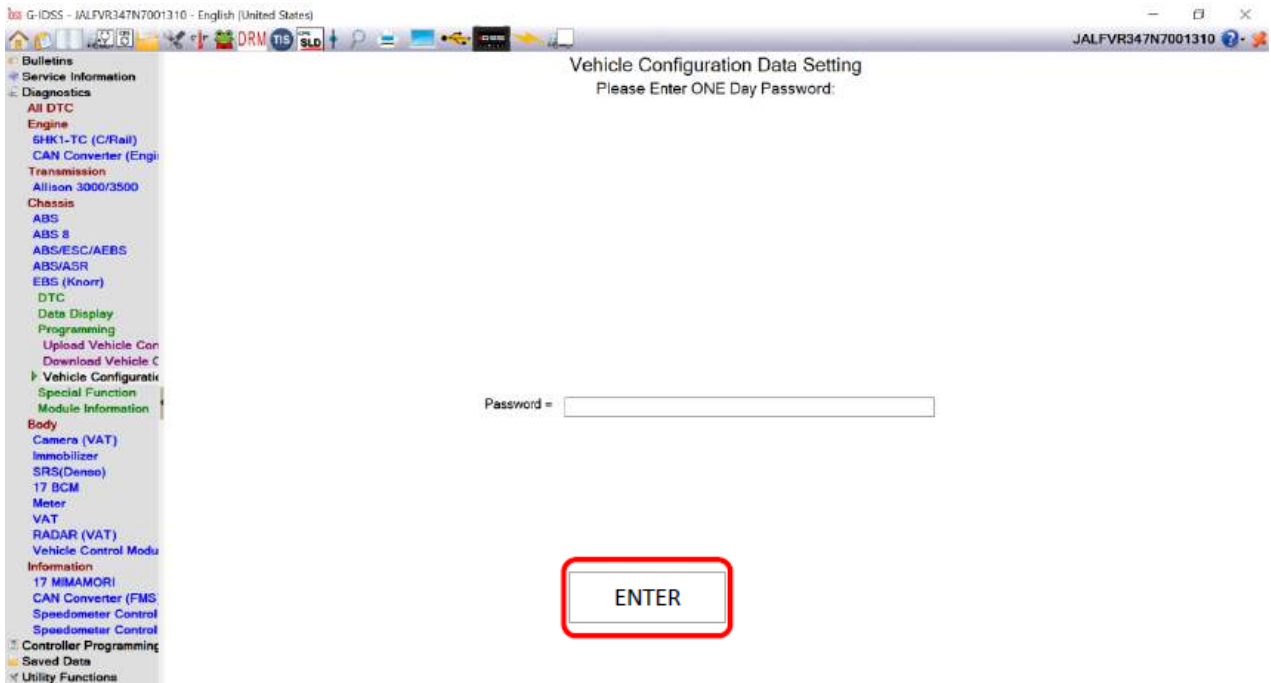

Figure 6 Contact Isuzu TAS to request a 24hr Password, enter your Password and Select ENTER

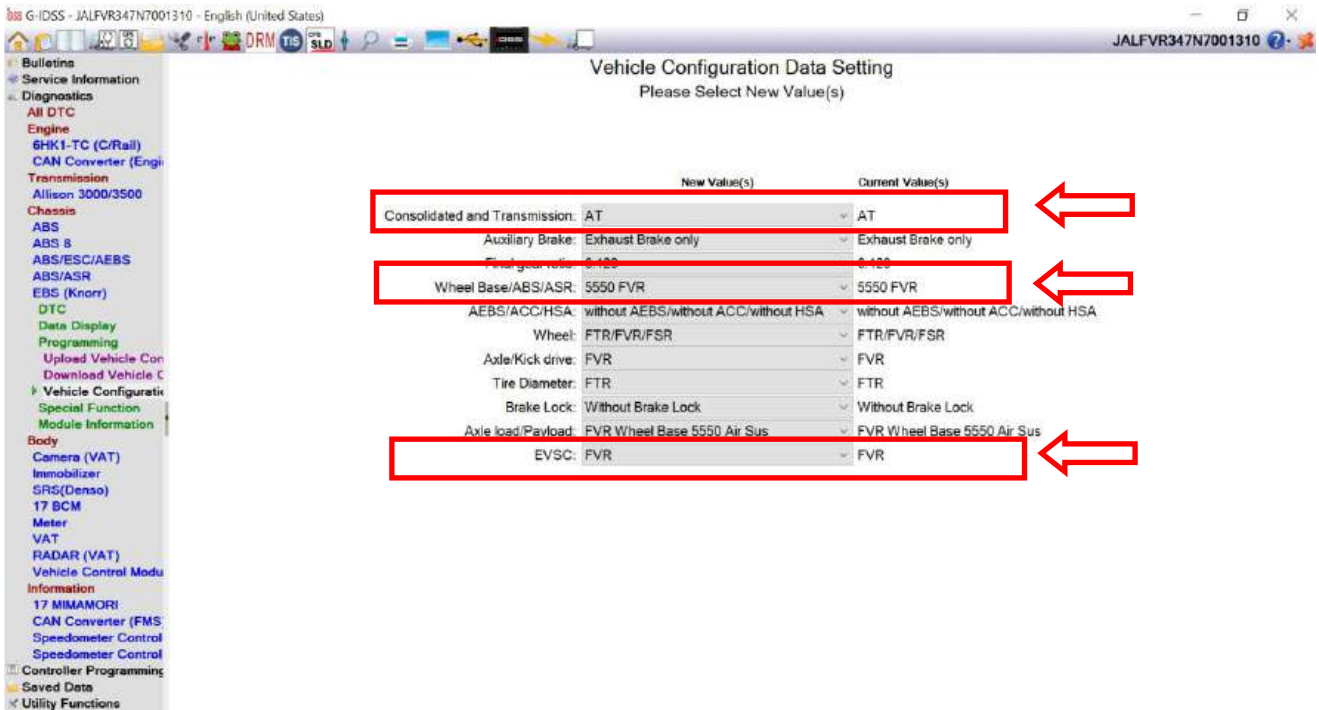

Figure 7 The three above highlighted sections will require programming. EACH AREA MUST BE PROGRAMMED ONE AT A TIME.

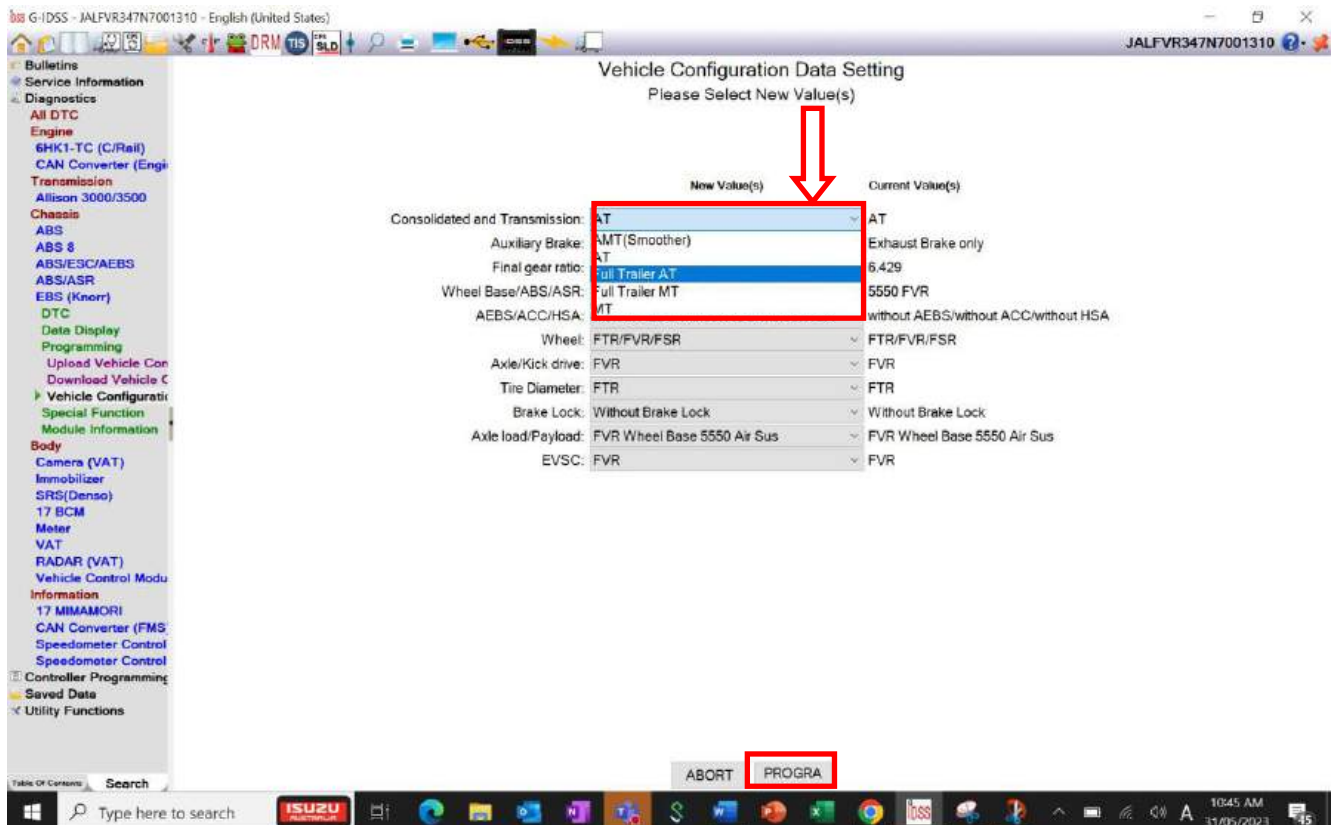

Figure 8 PROGRAM THIS SELECTION THEN PROCEED NOTE: You will need to restart the programming again and re-enter the 24hr Password to move back to be able to change the next data item.

NOTE: At times during the programming phase, GIDSS may indicate that the Programming Failed. If so check that data item was changed and if not reselect the programming item and try again.

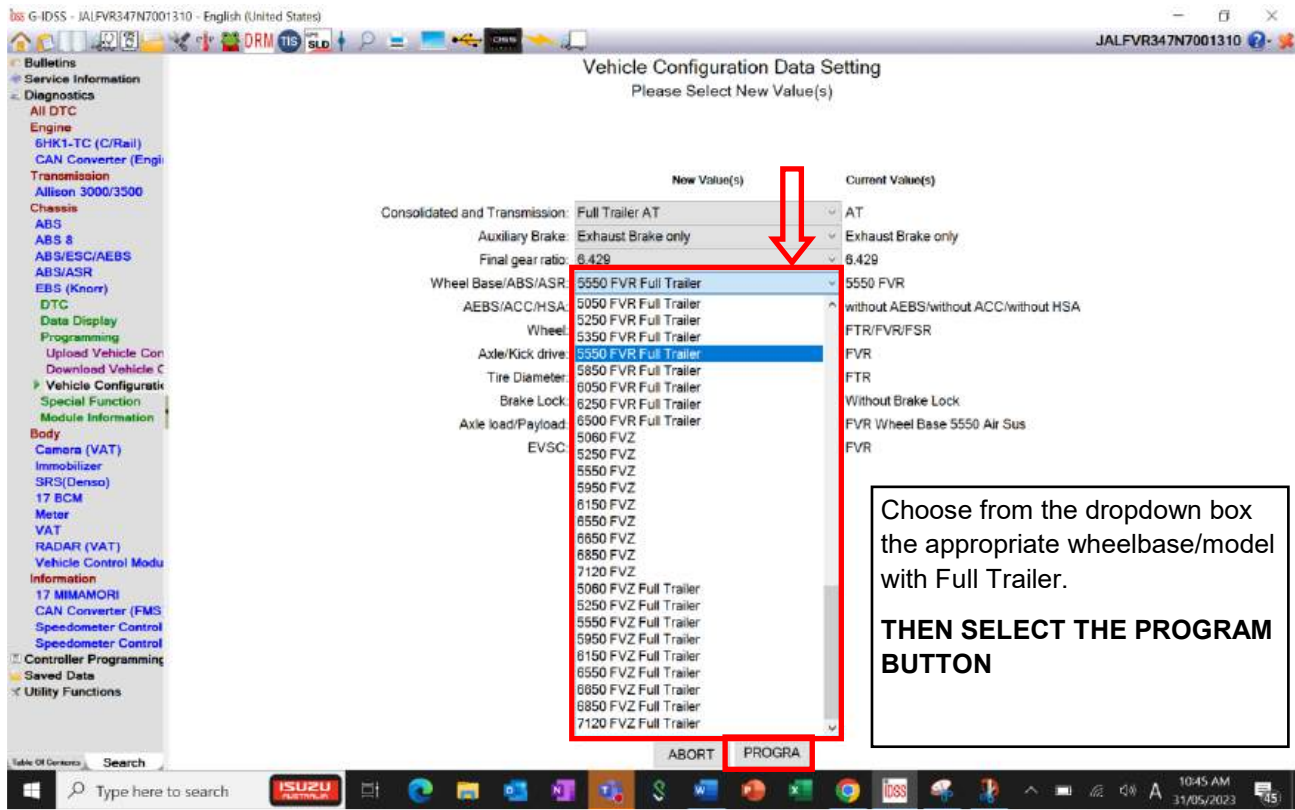
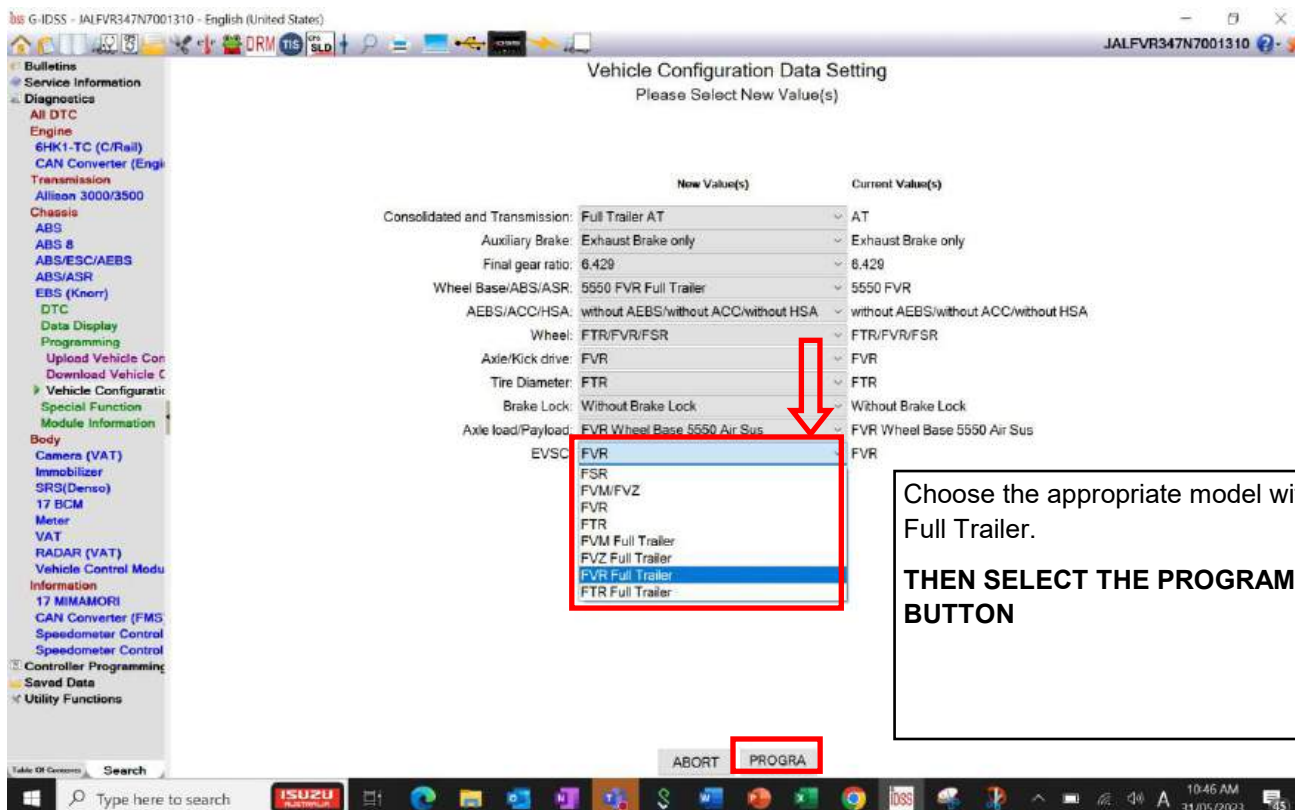

Figure 9 PROGRAM THIS SELECTION THEN PROCEED NOTE: You will need to restart the programming again and re-enter the 24hr Password to move back to be able to change the next data item.



Parameter	Value	Units
Consolidated and Transmission		
Auxiliary Brake	Full Trailer AT	-
Final gear ratio	Exhaust Brake only	-
Wheel Base/ABS/ASR	6.429	-
AEBS/ACC/HSA	5550 FVR Full Trailer	-
Wheel	without AEBS/without ACC/without HSA	-
Axle/Kick drive	FTR/FVR/FSR	-
Tire Diameter	FVR	-
Brake Lock	Without Brake Lock	-
Axle load/Payload	FVR Wheel Base 5550 Air Sus	-
EVSC	FVR Full Trailer	-

After Programming has successfully completed, recheck that all the changed data values are correct for your vehicle.

NOTE: A Screen shot of this page will likely be required by the AVE Certifier for evidence that the programming on the selected VIN vehicle has been performed correctly.

DTC Code	Description	Status
6HK1-TC (C/Rail) DTCs (1)		
P0571	Brake Switch Circuit	Not Present
CAN Converter (Engine) - No DTCs		
Allison 3000/3500 - No DTCs		
ABS - Unable to Connect		
ABS 8 - Unable to Connect		
ABS/ESC/AEBS - Unable to Connect		
ABS/ASR - Unable to Connect		
EBS (Knorr) DTCs (1)		
B0023	Trailer Control Module(TCM) installed But Not Configured Component	Not Present
Immobilizer - 1 DTCs		
SRS(Denso) - No DTCs		
17 BCM - Unable to Connect		
VAT - Unable to Connect		
Vehicle Control Module DTCs (1)		
C0023	86 Stop Lamp Circuit Communication or Input Data Malfunction (VCM)	Not Present
17 MIMAMORI - No DTCs		
CAN Converter (FMS) - No DTCs		

Recheck the ALL DTC's page and determine if all previous DTC's have changed their status to Not Present. Clear ALL DTC's.

NOTE: IT IS RECOMMENDED THAT A "RECOVERY WORK FROM FAILURE" procedure is performed.

1. Recovery work 1 from failure (Procedures by operating the brake pedal)

- 1) With the brake pedal released, turn OFF the ignition switch for 5 seconds or more.
- 2) Keep the following conditions, then turn ON the ignition switch for 7 seconds or more.
 - The vehicle is stopped.
 - The brake pedal is released.
 - The power supply voltage to the EBS control unit is sufficient.
- 3) Depress the brake pedal to the full braking position and hold for 3 seconds.

Caution:

- **Do not perform the pedal operation until 7 seconds have elapsed after the ignition switch was turned ON.**

PERFORM A FULL SYSTEM CHECK

Start the truck and air the system up to full pressure.

Check for air leaks using soap spray.

Confirm system works correctly.

Confirm all airlines and looms are secured.

Confirm all trailer lighting is operational.

Confirm EBS socket is operational and activate diagnostic light on dash cluster.

Once system check is completed Call AVE or VASS engineer for compliance check and blue plate.

System to be tested and certified by approved AVE to meet the requirements of VSB6 Section G2 Installation of Trailer Braking Controls.

